

Allegato A2

UHP-1000

UNIVERSAL SATELLITE ROUTER

SCPC

TDM/TDMA

Hubless TDMA

UHP-1000 satellite router is a universal software-defined component of highly-efficient satellite networks of any operation mode or topology. UHP-1000 can work as an SCPC modem with the satellite carrier fixed or assigned on-demand. It can also be a mini-hub or a remote station in TDM/TDMA network or any node (master or slave) in a fully meshed Hubless TDMA network.

Innovative algorithms for network access, resource allocation and data encapsulation as well as advanced modulation and coding, implemented in the UHP routers, ensure efficient utilization of satellite resources. Two built-in demodulators allow simultaneous reception of either TDM carrier from the hub and TDMA mesh carrier from two distinct satellite beams or from two antennas. Universal modulator can instantaneously switch from TDMA burst mode to SCPC mode, thus assuring high data throughput and efficiency.



UHP-1000 router is a compact and reliable device and can be installed on a work desk or in an equipment rack or inside a customized enclosure. Low power consumption and uniquely fast start on power-up facilitate use of alternative power sources, such as solar batteries. Integrated high-performance IP router supports different protocols and has expanded means for provision of Quality of Service (QoS).

UHP-1000 is a high-performance satellite router for a wide range of applications, such as enterprise networking, videoconferencing, distribution and contribution of video, voice and data trunking, cellular backhaul, and broadband Internet access.

- Various modes of operation and topologies: SCPC, TDM/TDMA, TDM/TDMA Mesh, Hubless TDMA
- Two demodulators with separate IF inputs and universal SCPC/TDMA modulator
- Superior productivity up to 60'000 pps and 150 Mbps aggregate throughput and 150 voice calls compressed
- Innovative TDMA protocol with LDPC coding and proven efficiency of 96% vs SCPC
- Ultra-low latency VSAT system with round-trip delay about 570 ms for TDMA mode of operations
- Support of VLAN, multi-level QoS, codec-independent handling of real-time traffic, TCP acceleration
- Built-in adaptive hierarchic traffic shaper specially designed for VSAT applications
- Capable of receiving carriers from two satellites simultaneously
- Built-in web-based management interface, user-friendly software configuration
- Fast network startup — network is ready for use in less than a minute upon power-up
- Low power consumption — less than 10 Watt (without RF ODU)
- Compatible with majority of C, Ku and Ka-band RF Systems, supplies power and reference signals
- Easy to install hardware and reliable operation with MTBF > 200'000 hours





UHP-1000 SATELLITE ROUTER SPECIFICATIONS

NETWORK

Topology	'point-to-point', 'hub and spoke', 'multilevel tree', 'mesh'
Modes of operation	SCPC, SCPC DA MA, TDM/SCPC, TDM/TDMA, TDM/TDMA Mesh, Hubless TDMA
Network size	up to 254 TDMA Inroute channels and 500 000 terminals per network

SCPC (TDM) CHANNEL

Symbol rate	from 300 kSps (250 kSps DVB-S) up to 32 MSps (34 MSps DVB-S)											
Modulation / Coding	FEC	1/3	2/5	1/2	3/5	2/3	3/4	4/5	5/6	7/8	8/9	9/10
	DVB-S (QPSK)	-	-	3.4	-	4.9	6.0	-	7.0	7.8	-	-
Demodulator Performance C/N, BER < 10 ⁻⁸	DVB-S2 (QPSK ACM-Long)	-	-	0.9	2.4	3.2	4.1	4.8	5.1	-	6.3	6.5
	DVB-S2 (8PSK ACM-Long)	-	-	-	5.7	6.9	8.2	-	9.7	-	11.1	11.3
	DVB-S2 (16APSK ACM-Long)	-	-	-	-	10.0	10.8	11.4	11.9	-	13.3	13.5
	DVB-S2 (32APSK ACM-Long)	Available with future software release										
	DVB-S2 (QPSK ACM-Short)	-0.9	-0.0	0.9	2.6	3.3	4.2	5.0	5.5	-	6.4	-
	DVB-S2 (8PSK ACM-Short)	-	-	-	7.6	7.5	8.6	-	9.9	-	11.3	-
DVB-S2 (16APSK ACM-Short)	-	-	-	-	10.3	11.0	11.8	12.2	-	13.4	-	
DVB-S2 (32APSK ACM-Short)	Available with future software release											
QoS	3-level prioritization, traffic polices, CIR, hierarchic 680-channel traffic shaper, PAF											

TDMA CHANNEL

Symbol rate	from 100 kSps up to 4 MSps	
TDMA Protocol	frame 30-100 ms, 9 slot sizes, manageable minimal bandwidth	
Modulation / Coding	FEC	2/3 5/6
	8PSK (LDPC)	Available with future software release
Demodulator Performance, BER < 10 ⁻⁷	QPSK (LDPC)	5.4 6.9
	8PSK (LDPC)	9.5 12.0
QoS	CIR, MIR, group QoS, hierarchic manager of TDMA bandwidth	

ROUTER

Performance	up to 60000 packets per second; 150 Mbps aggregate throughput; 150 voice calls compressed (cRTP)
Support	DSCP, multiple IP/VLANs, NAT, proxy ARP, L2 Bridging, TCP Acceleration
Protocols	DHCP, IGMP, SNMP, RIP, SMTP, TFTP, cRTP
Management	HTTP interface, SNMP, Telnet, NMS with VMO support

INTERFACES

User LAN port	Ethernet 10/100Base-T, RJ-45
Maintenance console	USB, B female
IF Rx	950-2050 MHz (LNB DC - 13.5V/18V 0.75A), F type
IF Tx	950-1750 MHz, -30...-5 dBm, (LO 10 MHz/+5 dBm, BUC DC - 24V / 2A), F type

MECHANICAL / ENVIRONMENTAL (IDU)

Power	176-283 VAC, 10 W
Operating temperature	0°...+50°C, humidity up to 90%
Size / Weight	147x144x29 mm / 530 g

romantis
Satellite communications
www.romantis.com | ulp@romantis.com

Europe, Middle East & Africa
ROMANTIS GmbH
Hilrenhalstraße 54,
12529, Berlin-Schönefeld, Germany
T: +49-30-585-90-4812
F: +49-30-545-90-8885

Americas and Asia
ROMANTIS Inc.
6900 Trans-Canada Highway, Suite 725, Pointe-Claire (Montreal), Quebec, Canada H9R 4S2
T: +1-514-695-VSAT (8728)
F: +1-514-697-0180

Ku-band 1W / 2W / 3W Block Upconverter

MODEL NO. NJT5035 135F

MODEL NO. NJT5036 / 36F

MODEL NO. NJT5037 137F

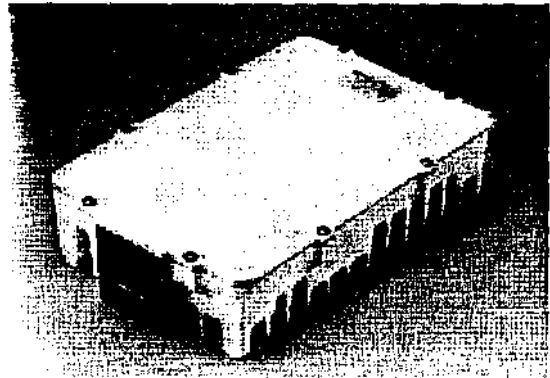

Features >

- * Small Size & Light Weight
- * High Efficiency Output Power
(1W / 2W / 3W @P1 dB over temperature)
- * Low Power Consumption
- * RoHS Compliance

Line-Up >

Model	RF. Frequency	Local Frequency	IF Frequency	Output Power	Connector
NJT5035	14.0 to 14.5 GHz	13.05 GHz	950 to 1,450 MHz	1W	N-Type
NJT5035F				30 dBm min.	1111-11
NJT5036				21V	ME
NJT5036F				(+33 dBm min.)	1.21
NJT5037				3W	1.21
NJT5037F				(+35 dBm typ.)	F-Type

Specifications >

Item	Specifications
Output Interface	Waveguide, WR-75
Output Power @ P1 dB	+30 dBm minimum average temperature [NJT5035/35F] +33 dBm minimum average temperature [NJT5036/36F] +35 dBm typical, +33 dBm minimum average temperature [NJT5037/37F]
Conversion Gain	50 dB nom. [NJT5035/35F] 53 dB nom. [NJT5036/36F/37/37F]
Phase Noise (SSB)	-60 dBc/Hz max. @ 100 Hz -70 dBc/Hz max. @ 1 kHz -80 dBc/Hz max. @ 10 kHz -90 dBc/Hz max. @ 100 kHz
Required External Reference Signal	Frequency: 10 MHz Input Power -5 to +5 dBm Phase Noise: -125 dBc/Hz max. @ 100 Hz -135 dBc/Hz max. @ 1 kHz -140 dBc/Hz max. @ 10 kHz
Input Interface	N-type, female (50 ohm) [NJT5035/36/37]
Input/ Output V.S.W.R,	20:1 max. @ Input 20:1 max. @ Output
Mute	Shut off the HPA in case of LO unlocked
Power Requirement	+15 to +30 V dc

Item	Specifications
Power Consumption	24 W max. [1\1JT5035/359 26 W max. [NJT5036/369 30 W max. [NJT5037/37FI
Operating Temperature	-40 to +55 degrees C
Storage Temperature	-40 to +75 degrees C
Size	191.8 mm (L) x 119 mm (W) x 4.5 mm (H) [7.55" (L) x 4.69" (W) x 1.75" (H)] (WT5035/36/37) 186.7 mm (L) x 119 mm (W) x 44.5 mm (H) [7.35" (L) x 4.69" (W) x 1.75" (H)] (NJT5035F/36F/37F)
Weight	1.2 kg max. [26 lbs]

<flutime Thawng

Typel (N-type Female input Connector): :
NJT5035/36/37

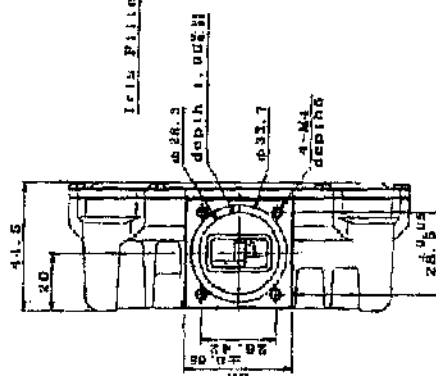
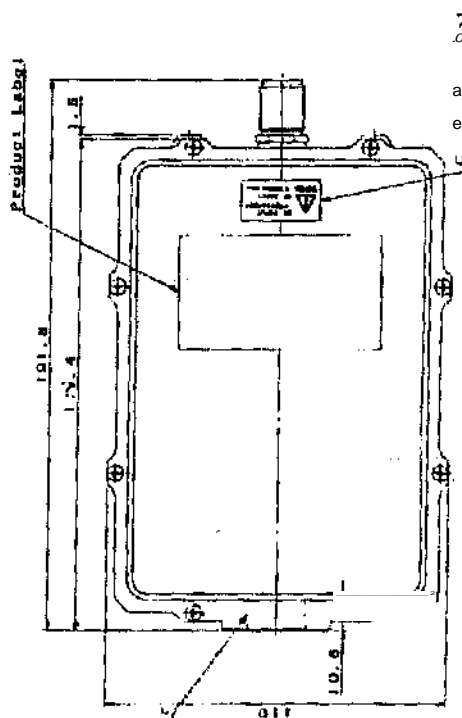
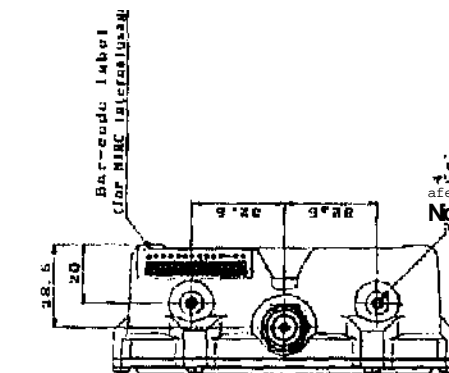
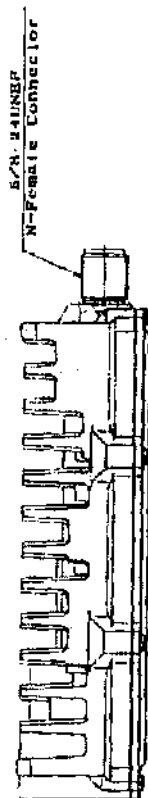
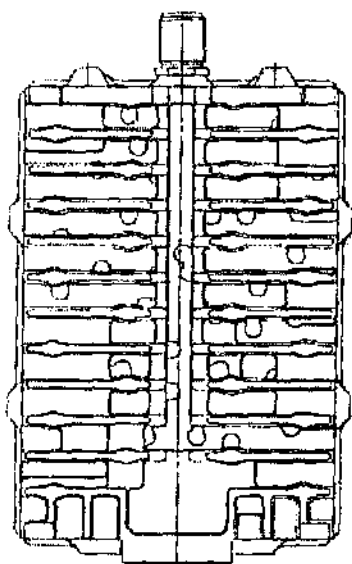

Unit: mm_t

Type2 (F-type Female Input Connector):
 NJT5035F136F137F

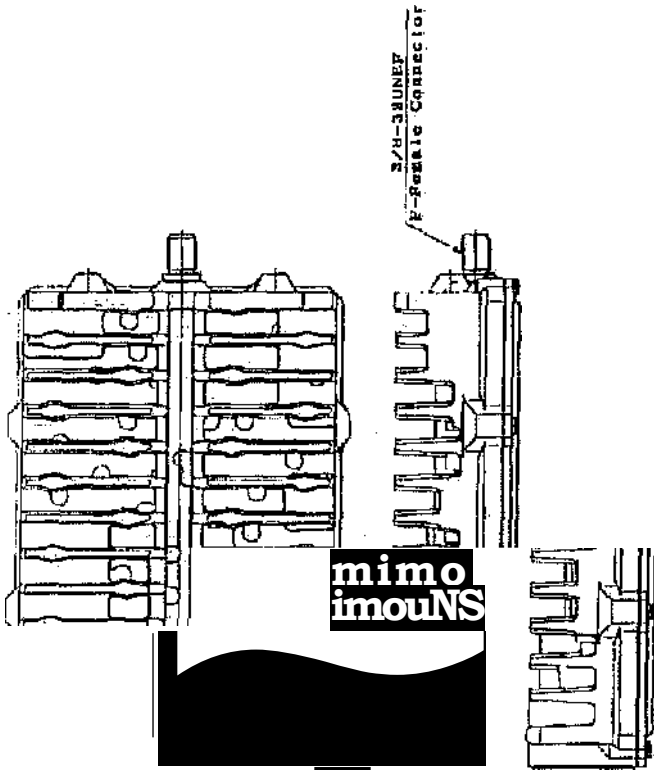

Una: mm

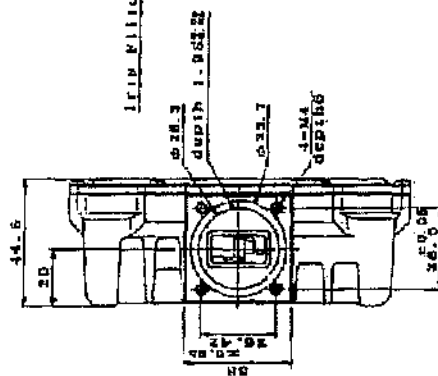
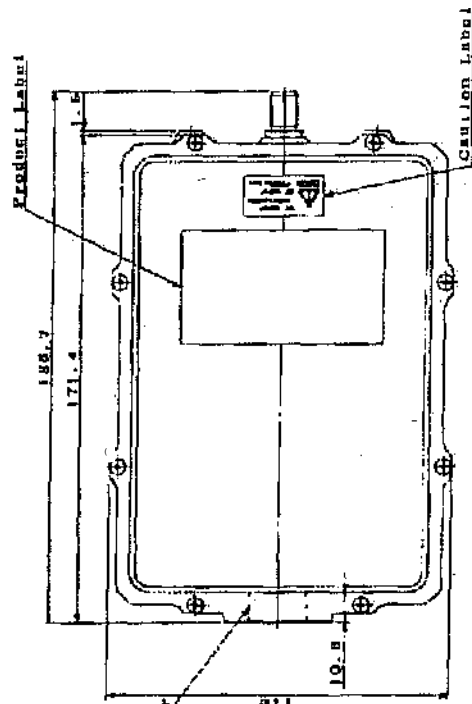
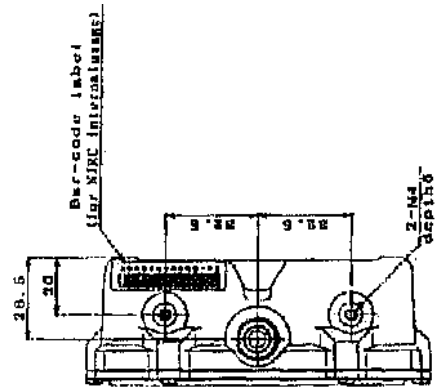

*Nelagoars Radio ect,1.*Z*

Microwave Components DMsion
 1-1, Fukuoka 2-Chome, Fujimino-City SAITANIA, 356-8510 JAPAN

E-mail : mcsales@njrco.jp

Phone : +81-49-278-1270

FAX : +81-49-278-1234

<http://www.njr.co.jp>

Ku-band DRO LNB (LO Stability: +1-900 kHz]

MODEL NO. NJR2784H

MODEL NO. NJR2744H

MODEL NO. NJR2754H

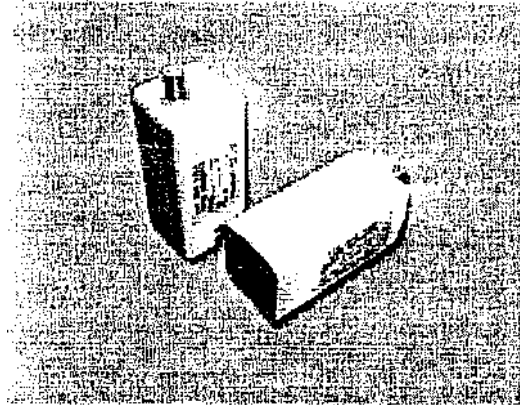

< Features >

Low Noise Figure

*** RoHS Compliance**

< Line-Up >

Model No.	RF Frequency	Local Frequency.	Local Stability -40 to. +60 C	IF Frequency	7 g Connector
NJR2784H	10.95 to 11/0 GHz	10.00 GHz	+/- 0.9 MHz	950 to 1,700 MHz	F-type
NJR2744H	11.70 to 1220 GHz	10.75 GHz		950 to 1.450 MHz	
NJR2754H	1225 to 1275 GHz	11.30 GHz		950 to 1,450 MHz	

< Specifications >

	Specifications
Input Interface	VVR-75
Output Interface	F-type, female (75 ohm)
Noise Figure	0.6 to 0.8 dB
Conversion Gain (at 25C)	55 dB
Conversion Gain Variation (at 25C)	2 dB p-p max. In any 50 MHz segment over the frequency band
Phase Noise (SSB)	-65 dBc/Hz @ 11(Hz) -90 dBc/Hz @ 10 kHz -110 dBc/Hz @100 kHz
Power Requirement	+15 to+24Vdc
Operating Current	110 mA
Operating Temperature	-40 to +60 degrees C
Storage Temperature	-40 to +80 degrees C
Size	822 mm (L) x 40 mm (W) x 40 mm (H) [324' (L) x 137' (W) x 1.57" g-1]j
Weight	_210 g max. [0.48 lbs]

<Online Drawing>

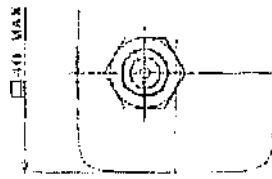

2

REF

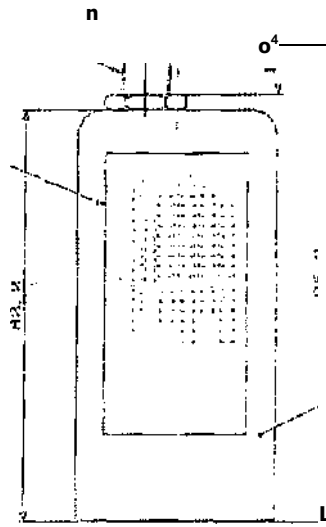

2
to

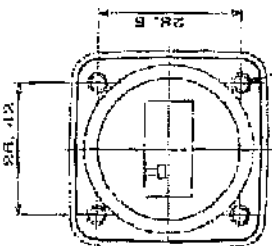

Lo

.Te*
7.14

Unit mm

Afe*, 9apartRatlia eallf

Microwave Components Division
1-1, Fukuoka 2-Chome, Fujimino-City SAITAMA, 356-8510 JAPAN

E-mail : mcsales@njr.co.jp

Phone : +81-49-278-1270

FAX : +81-49-278-1234

<http://www.njr.co.jp>

